

Shirts, Trewes, & Hose .ij. :

Documentable Details

by maister Emrys Eustace, hight Broom

So very few examples survive of medieval underwear, that this particular section of costume research is forced to reprint drawings and photos of (now) long-lost pieces. Kohler brings us our first example:



218. Priesterhemd aus dem 14. Jahrh.

Kohler's "14th-c priest's shirt", now lost.

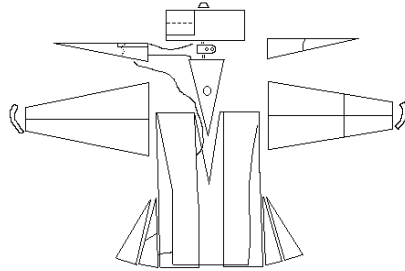

The **Chelles Shirt**, ca 1100s.

Carlson: "Pattern drawing based on a photograph of the original drawing, and may not be completely accurate"
 "This was based on a photograph sent by "Liebaart" liebaart@tiscali.net be to 75years@yahoogroups.com. This shirt was supposedly one that was owned by Thomas Becket (1120-1170) and is now in the Abbey of Chelles."

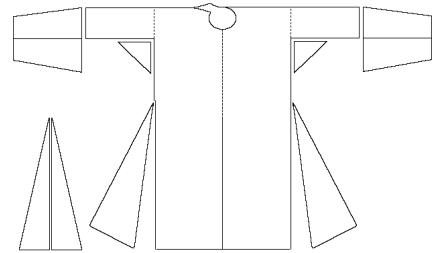

The **Arras Shirt**, ca 110s.

Carlson: "Pattern drawing based on a photograph of the garment, and may not be completely accurate"

"This was based on a photograph sent by "Liebaart" liebaart@tiscalinnet.be to 75years@yahoogroups.com. This shirt was supposedly one that was owned by Thomas Becket (1120-1170) and is now in the Cathedral of Arras. It is made from fine linen. The side gores have very small folds on their tops."

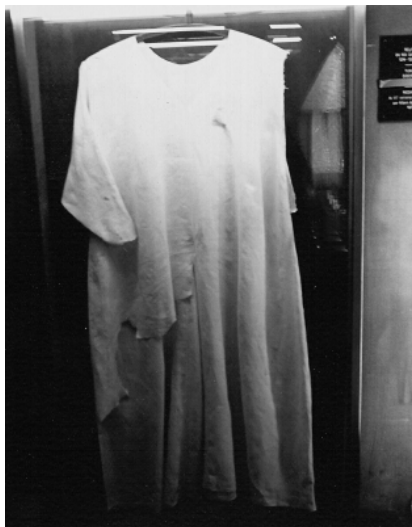

Picture of the **St Louis Shirt**, from Revival Clothing (www.revivalclothing.com). See their site for two more photos:

<http://www.revivalclothing.com/index.asp?PageAction=Custom&ID=19>

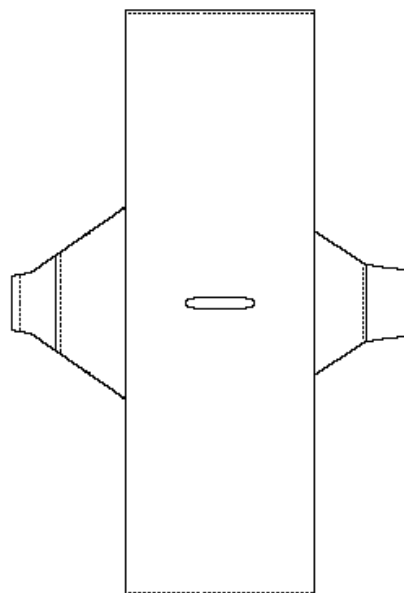

← **Rogart Shirt**

Carlson: "Drawing is based on Henshall"

With a vague provenance, the Rogart shirt is of coarse linen or wool (sources differ) of varying weaves (within the same fabric piece!). It was found in a grave near Parish of Rogart, Sutherland. Possibly dated to the 1300s. Of especial note to us, the edges of the (single-piece) body are selvages, sewn together from armseye to hem. Approximately 45" tall from shoulder to the 61.5" hem. Blanket stitches secure the corners of the neckline; most other joins use a double-rolled edge (which, as we shall see, is common in medieval linen construction).

The asymmetrical sleeves are notable. Sloppy (post-period) reconstruction? Or possibly a hackneyed repair during the wearer's lifetime?

And that's almost we have for extant shirts — yet this is a treasure trove next to what survives of trowes (perhaps, not surprisingly). We are a little luckier in hosen findings, which will be discussed in the next class, and the odd coif survives.

Reconstructing the St. Louis Shirt

Given this, we still can reproduce some medieval underwear, with assurance that we are pretty close to the original in all aspects. The St. Louis shirt seems to be our best surviving example of (non-hosen) medieval underwear. Let's take a look at reproducing this piece; yet, there is still confusion over the exact measurements and construction, since a detailed examination of the garment has apparently not been made.

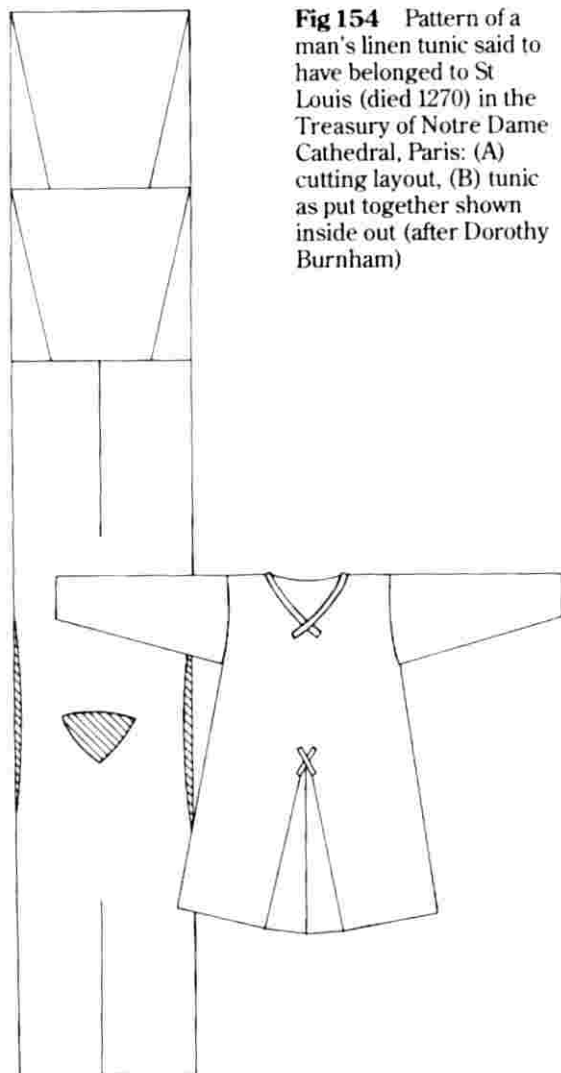
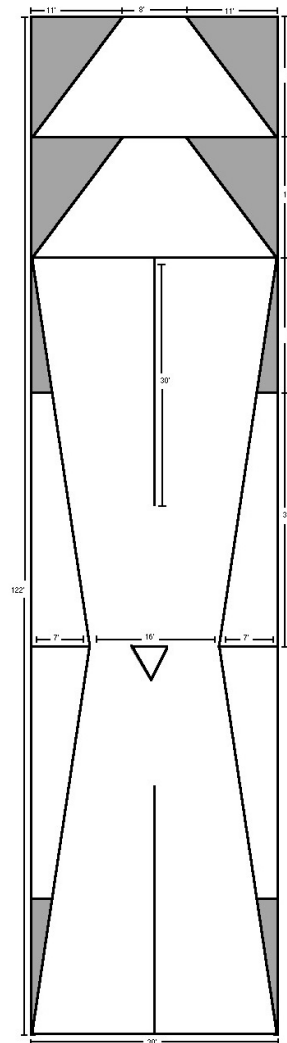
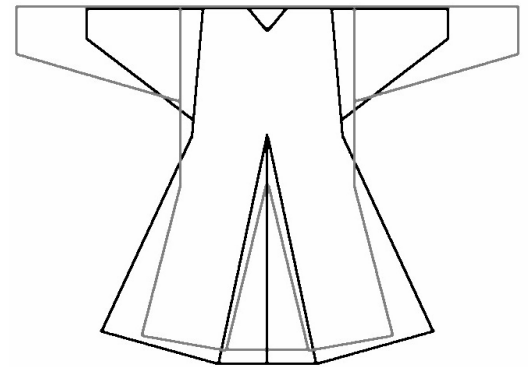

Fig 154 Pattern of a man's linen tunic said to have belonged to St Louis (died 1270) in the Treasury of Notre Dame Cathedral, Paris: (A) cutting layout, (B) tunic as put together shown inside out (after Dorothy Burnham)

Illustration from T&C, after pattern layout diagram by Dorothy K. Burnham, *Cut My Cote* (Royal Ontario Museum, 1973, reprinted 1997)



Pattern layout by Heather Rose Jones, 2001 (but note subtle change, curving the armscye, in commentary to right).



Comparison of reconstructions based on these two layouts. (Jones's diagram yields the darker-lined tunic.)

Stephen Bloch and Deborah Peters disagreed *slightly* with Jones' reconstruction, apparently convincig Jones:

"The armscyes, it seemed to us, were quite clearly curved and angled: at the top, they were cut approximately on the grain (perhaps even angled inward a tad), while at the bottom they were at almost a 45-degree angle to it. I remembered you saying something about following grain lines, although I didn't remember what measurements you came up with, so I did the same -- not only from the bottom of the armscye to the hem, but from top to bottom of the armscye. The former measurement came out 3-4" (which, I now see on re-reading your article, matches your result), but the latter is recorded in my diary as 4-6"! This is decidedly more angled (and, as mentioned above, curved) than even Burnham says.

Jones: "The wrist and hem edges have a small rolled hem about the same width as the seam finish (i.e., 2-3 mm). This is rolled to the 'outside' of the garment as displayed, and the seam finishes are also 'outside' as displayed. I strongly suspect that the garment is being displayed inside-out and that these features should actually fall on the inside of the garment, but it's hard to complain about the display since the details would be impossible to examine otherwise!



Detail photos of the shirt taken by Stephen Bloch, from Heather Rose Jones' article

Jones: "The tape that Burnham shows in her diagram at the neck and the top of the gusset actually represents a seam finish that is present on all the visible seams of the garment. At all places where it is visible, this seam-finish is cut on the straight grain of the fabric. In addition to the neck edge, it is present on the seam attaching the sleeves to the body, on the lengthwise sleeve seam, on the side seams of the body, and on all seams involved in the central gussets.... [T]he finished width is about 2-3 mm, and the fabric used must have been about twice that before the edges were folded under.... The top of the gusset is slightly gathered for a couple of centimeters, rather than being entirely flat.



Jones' cross-section reconstruction of 2-3 mm. seam treatment.

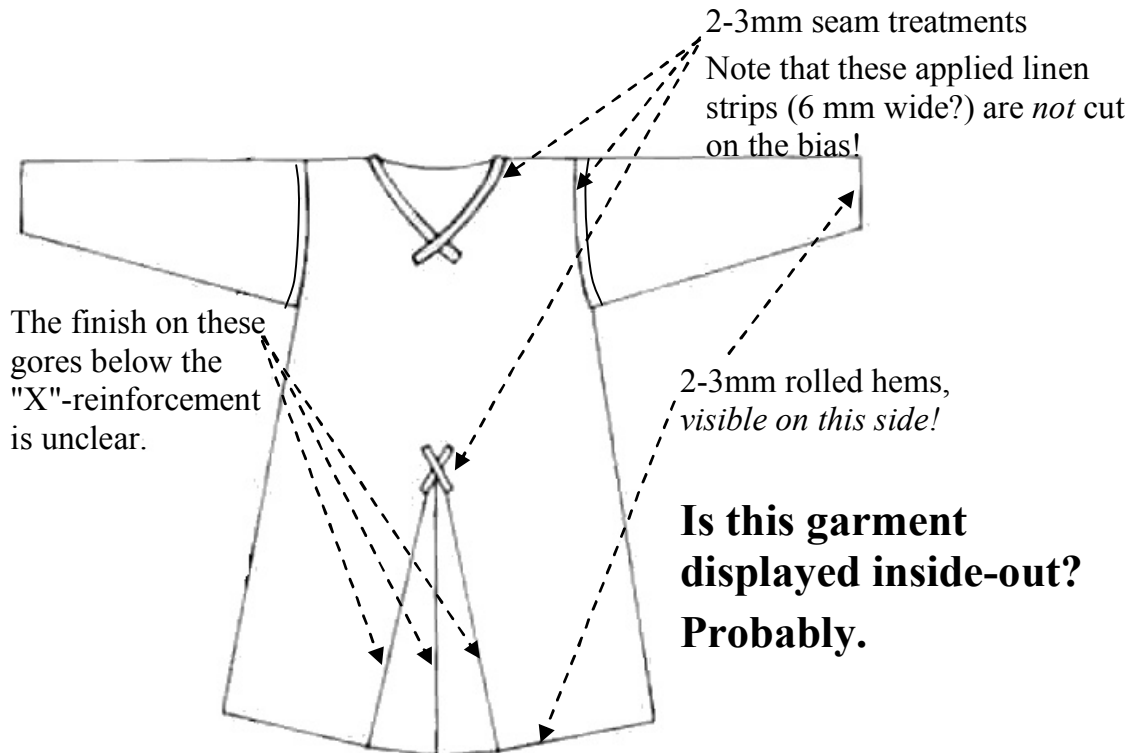

Sewing Overview

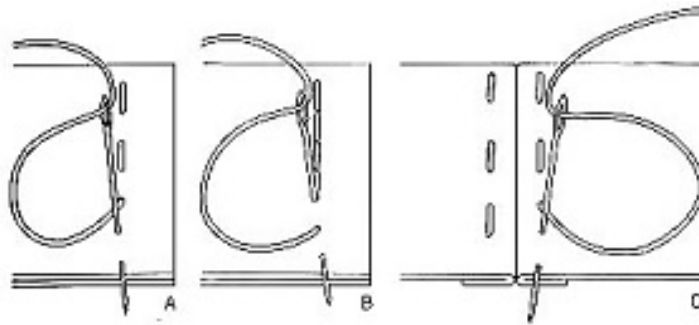

Fig 126 Seams joined by (A) running-stitch, and (B) back-stitch; (C) seam opened flat and reinforced with running-stitch

Seam construction seen on *wool* garments. T&C pl. 56.

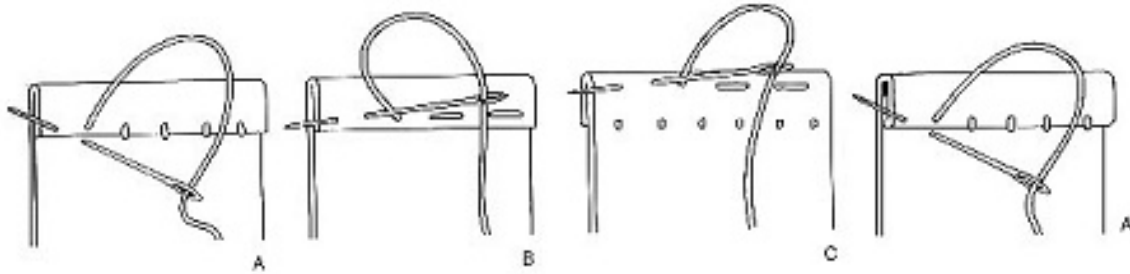

Fig 127 Single-folded hems: (A) hem-stitch, (B) running-stitch, (C) top-stitch

Fig 128 Double-folded hems: (A) hem-stitch

Figure 1 Seam construction seen on *linen* garments. T&C pl. 57.

From T&C p 158: "All surviving facings and bindings are of a fine tabby silk on the straight grain of the fabrics; **no bias strip is known to have been used for this purpose on bias-cut or curving edges.**"

Note that they are not stating that bias-cuts were not used, but that they were not known to have been used for bias facings & bindings.

Regarding rolled hems (same page): "The technique is used solely on the fine transparent silk veils of the late 14th-century... where it has proved most efficient as well as unobtrusive."

Buttons & Buttonholes

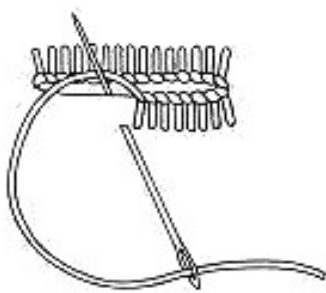
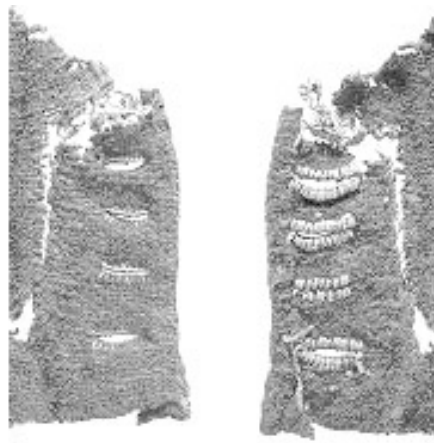
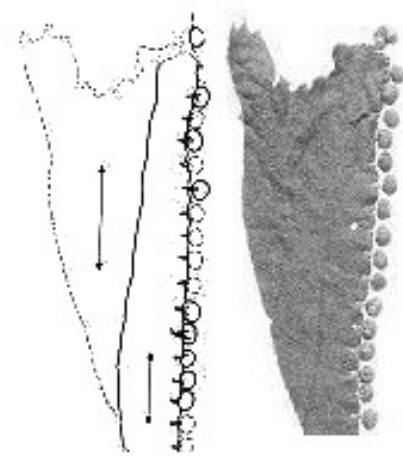

Fig 145 Method of sewing buttonholes

Buttonhole stitch, T&C p 170



Buttonholes, T&C p 170



Buttons, T&C p 169

Braided cords

Probably every young medieval girl learned at least a couple of different ways to fingerbraid. From simple yarn a cord as strong as desired can thus be made cheaply. T&C [138-42] documents fingerloops with from 5 to 20 loops each, as well as plaited braids (unlooped ends), and tabby-woven (plain weave) ribbons. Any of these could be used as a cinch cord, lace, or hose point. All of the T&C London finds were of silk (the strongest medieval fiber), and all but one were monochrome.

Both fingerloop braids and sprang cords have been found. See the references at the end of this article for instructions on making medieval cords.

Neckline Facing

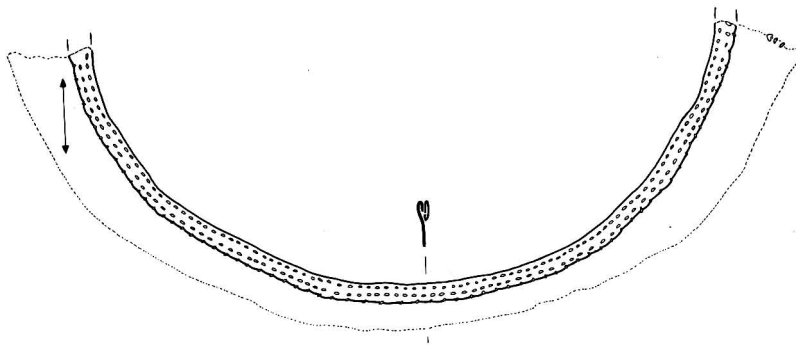

Neckline of a wool garment with a narrow silk facing, No 50, shown from the reverse, from a deposit dating to the second quarter of the 14th century. T&C p 160

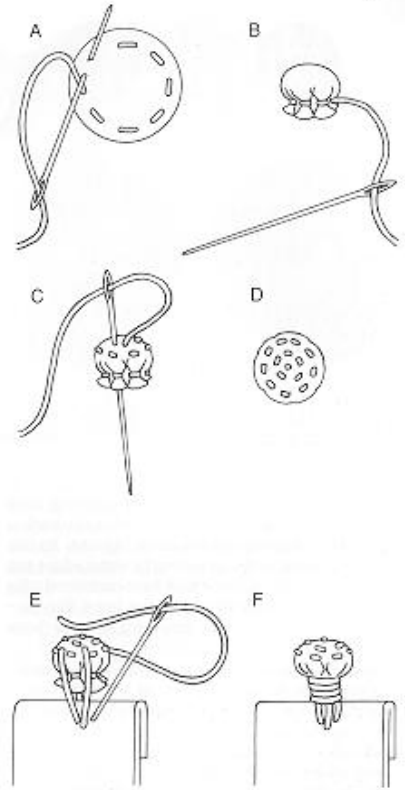

Fig 147 Method by which some of the buttons were made and attached

Cloth button construction, T&C p 171

Eyelets

Fig 87 of Janet Arnold's *Patterns of Fashion* is a photograph of eyelets used in breeches from 1574 Florence. These eyelets have a thin metal ring that is oversewn (or "buttonstitched") to reinforce the holes. Bodices of this period were reinforced in similar ways, to take the stress of tight-lacing.

This page also shows sets of hook & eyes in two other garments. Page 24 also has examples of hook and eyes, sewn eyes, and buttonholes. Fig. 151 states that hooks and eyes were still new and that they would soon displace and replace the use of points in clothing, at the end of our period, c1605-1610. Thus, Arnold seems to believe that eyelets in our period were probably not reinforced with metal eyelets, which agrees with the archaeological evidence with which I am familiar.

Fig 138 Detail of eyelet holes on silk facing and associated strip of silk, No 329, from a deposit dating to the late 14th century: (A) front, note traces of the woollen cloth to which the facing was originally stitched are visible round the eyelet in the centre, (B) reverse, (C) associated strip with two rows of stitching holes down the centre. Scale 1:1

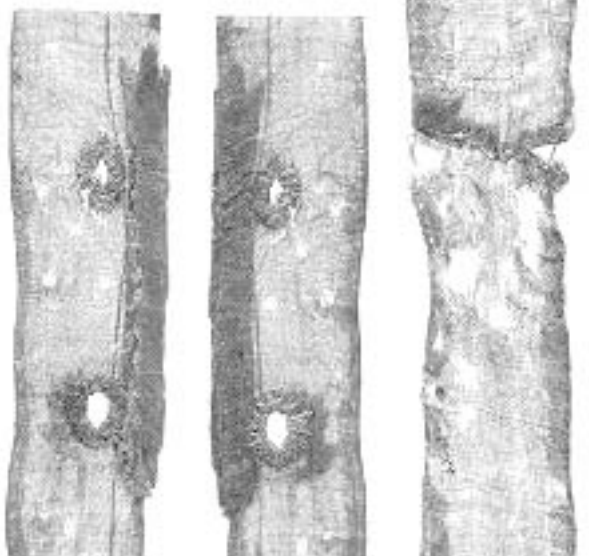
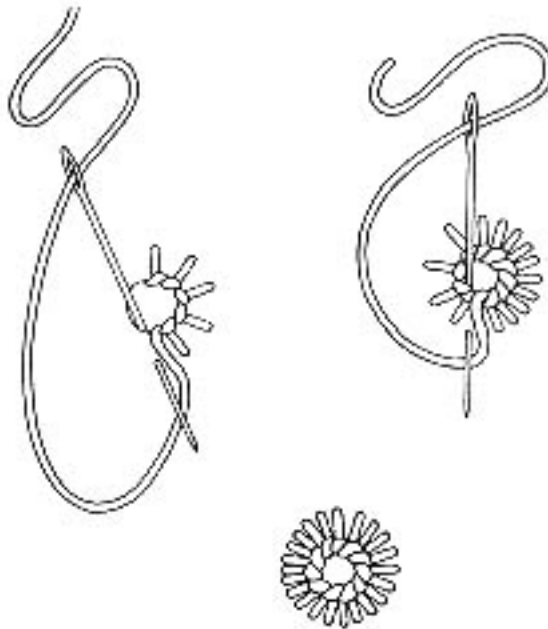

Fig 139 Diagram showing how the eyelets were stitched on No 329



Eyelet construction & examples, T&C p. 164

Bibliography

- Arnold, Janet. *Patterns of Fashion - The Cut and Construction of Clothes for Men and Women c 1560-1620*.
- Boucher, François. *20,000 Years of Fashion. The History of Costume and Personal Adornment (Expanded Edition)*. (Harry N. Abrams, Inc., NY 1983). ISBN 0-8109-1693-2.
- Carlson, R. Marc (Master Diarmaid O'Duinn). <http://www.personal.utulsa.edu/~marc-carlson/cloth/bockhome.html> and <http://www.personal.utulsa.edu/~marc-carlson/cloth/alphindex.html>
- Crowfoot, Elisabeth; Frances Pritchard, and Kay Staniland. *Textiles and Clothing, c.1150-c.1450. (Medieval Finds from Excavations in London: 4)* (alias "T&C") (London: HMSO, 1992).
- Goslee, Sarah (Mistress Phiala O'Ceallaigh). Resource for both fingerloop braiding and sprang. <http://www.stringpage.com/index.html>
- Kohler, Carl. *A History of Costume* (New York: Dover 1963/1928).
- Priest-Dorman, Carolyn (Póra Sharptooth). <http://www.cs.vassar.edu/~capriest/fingerloop.html>
- Revival Clothing. www.revivalclothing.com
See their site for two more photos:
<http://www.revivalclothing.com/index.asp?PageAction=Custom&ID=19>
- Jones, Heather Rose (Mistress Tangwystyl verch Morgant Glasvryn). *Another Look at St. Louis' Shirt* (© 2001, 2004). <http://heatherrosejones.com/stlouishshirt/index.html>
Also see, because it's cool: *The Surviving Garments Project*. <http://heatherrosejones.com/survivinggarments/index.html>